

BATTERY TERMINAL CRIMPING TOOL

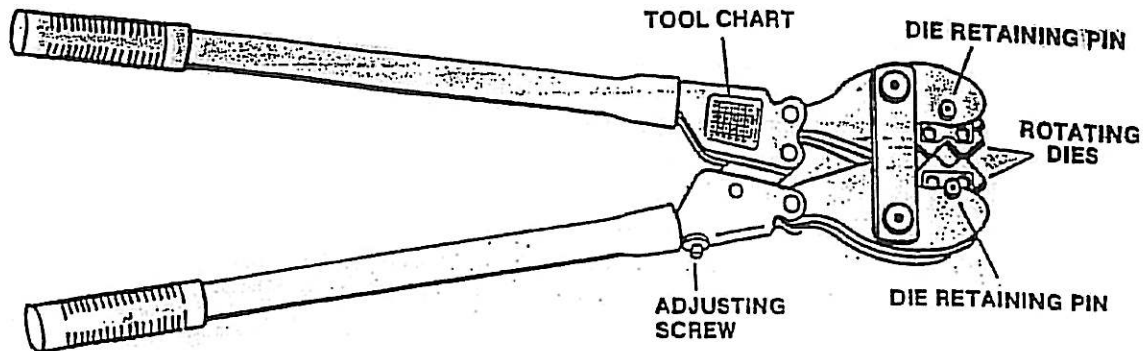

TOOL INSTRUCTIONS

1. Shut off all power to cable before starting work.
2. Select the proper size connection to fit the cable being used.
3. Strip and remove cable insulation to a length approximately 1/8" longer than length of connector barrel.
4. Fully insert stripped cable end into connector.
5. Check crimping tool for correct die setting as indicated on tool chart (see tool). If die setting is to be changed, spread tool handles to fully opened position, depress die retaining pin, and rotate die to position desired.
6. Position Battery Terminal between dies so that first crimp will be made in the middle of the Terminal Barrel:
7. Close the tool so that the dies crimp the connector at approximately the mid-point of the connector barrel. Close handles of the tool completely.
8. On sizes requiring more than one crimp, make additional crimps moving towards the cable entrance of connector.

NOTE: Heat Shrink Tubing will ensure a long-lasting, corrosion-free connection.

TOOL CALIBRATING

1. Set left die to "A" position. Set right die to "C" position.
2. Open tool fully and then close handles until right and left die first touch. Stop at this point. Measure the distance between handle ends. The distance should be approximately 14-16 inches.
3. To adjust handles, turn adjusting screw clockwise to increase distance between handles (counter-clockwise to decrease).

